

4 DIFFERENT AIRFLOWS IN 1 DESIGN

AR75 SELF-REGULATING WINDOW VENTILATION

- Self-regulating natural ventilation in the highest class, without energy loss
- 4 Different flows in one uniform front sight
- Safe ventilation with closed windows : insect proof, burglar-proof and waterproof



AR75

INTRODUCTION

Thermally broken self-regulating aluminium vent, suitable on aluminium, timber and uPVC windows. Due to its unique patented mechanism, 4 different airflows of 56, 70, 81, 106m³/h/m can be reached, while maintaining the full range of control.

The self-regulating flap reacts automatically to various wind pressures and can not be directed by the user himself. This self regulating principle prevents draughts and saves on energy costs for the end-user. The inner flap, which acts as an insect mesh, is easy to take off for maintenance purposes.

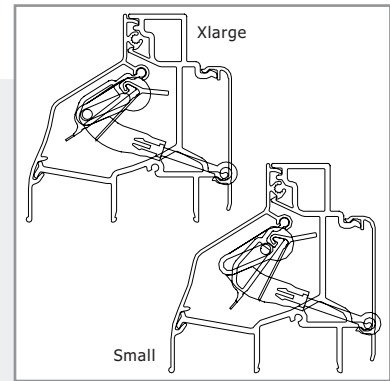

CONTROLS

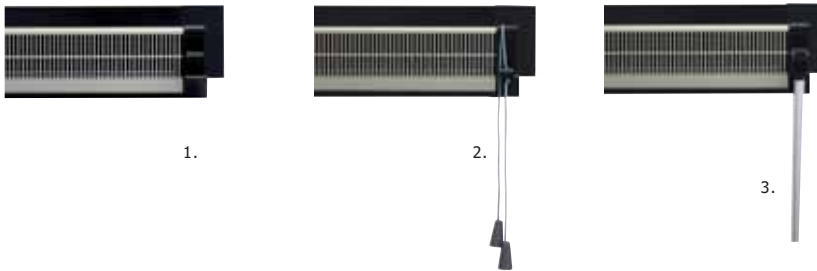

1. Manual control
2. Cord control - left or right
3. Rod control - left or right - white, black, satin anodised or RAL-colours



TECHNICAL FEATURES

- Small : - 56 m³/h/m (2Pa) - 52 m³/h/m (10Pa)
- Medium : - 70 m³/h/m (2Pa) - 73 m³/h/m (10Pa)
- Large : - 81 m³/h/m (2Pa) - 93 m³/h/m (10Pa)
- Xlarge : - 106 m³/h/m (2Pa) - 105 m³/h/m (10Pa)
- Insectproof
- Overall height : 92 mm
- Glass reduction : 75 mm
- Surface : 0,075 m²
- Glass thickness : 20, 24, 28, 32
- Water tightness : 50 Pa (open condition), 650 Pa (closed condition)
- Sound reduction : D_{n,e,w} (C,Ctr) in dB : 27,2 (0,-1) dB in open position
43,0 (-1,-2) dB in closed position
- U-value : 3 W/m²K
- Equivalent area : Small 13 790 mm²/m
Medium 17 780 mm²/m
Large 22 860 mm²/m
Xlarge 26 670 mm²/m

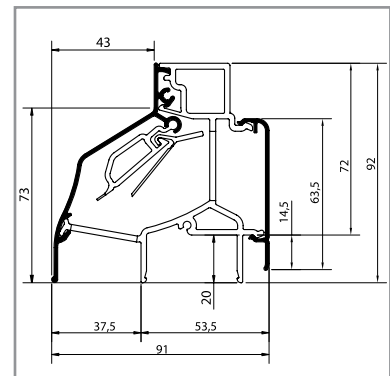

Conditional technical changes • The most recent edition of the brochure can be downloaded on www.renson.eu

RENSON Ventilation • IZ 2 Vijverdam • Maalbeekstraat 10 • B-8790 Waregem
Tel. +32 (0)56 62 71 11 • Fax +32 (0)56 60 28 51 • info@renson.be • www.renson.eu
RENSON Fabrications LTD (UK) • Fairfax Units 1-5 • Bircholt Road
Parkwood Ind Est Maidstone • Kent • ME15 9SF • Sales Tel. 01622/754123
Fax 01622/689478 • Fax 01622/689479 • info@rensonuk.net • www.renson.eu

 **RENSON**
INNOVATION IN VENTILATION